

Single-Deck Wide Island

Wide island configuration offers increased product capacity either alone or with OWEZV endcap. Double bin design for frozen food, ice cream and medium-temperature applications with dual-temperature capability.



Model OWIZV Single-Deck Wide Island

Case Cross Section

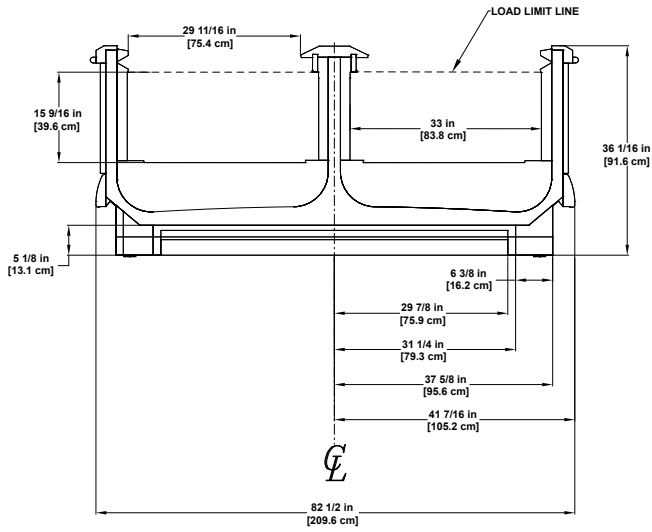

Superstructure Options

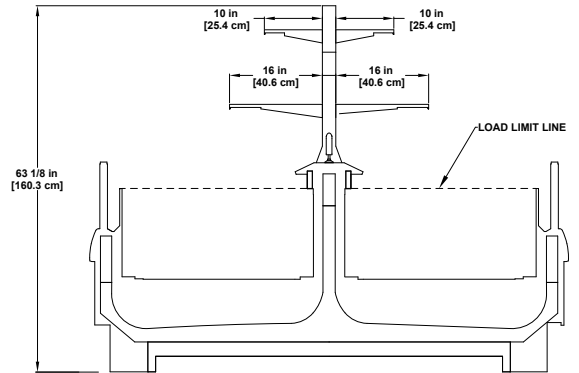
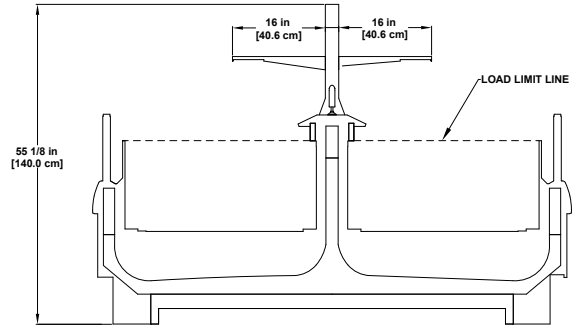
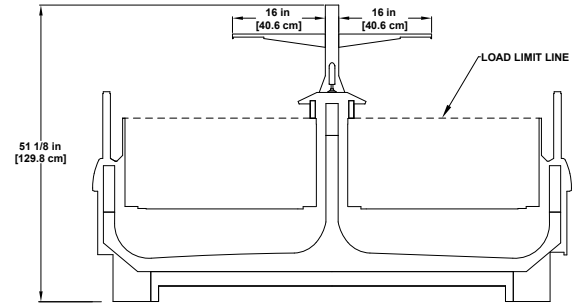

Please consult Hillphoenix Engineering Reference Manual for dimensions, plan views and technical specifications. Specifications subject to change without notice. Designed for optional performance in store environments where temperature and humidity do not exceed 75 degrees and 55% R.H. Certified to UL 471 and ANSI/NSF Standard 7.

Front Options

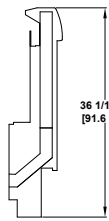

Solid

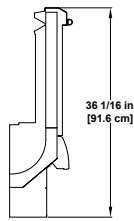

Classic 2

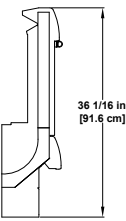

Fusion

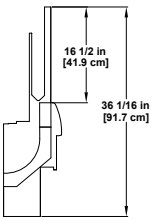

17" Glass Streamlyne

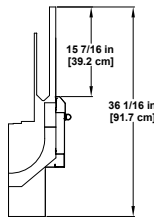

17" Glass Flat

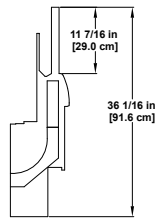

12" Glass Streamlyne

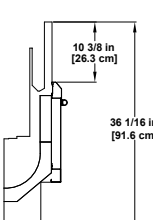

12" Glass Flat

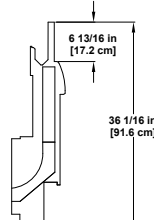

7" Glass Streamlyne

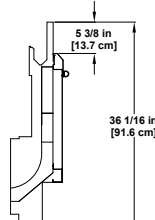

7" Glass Flat

End Options

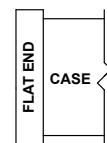
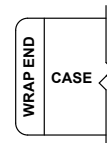
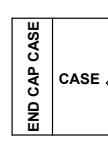

Case Configurations

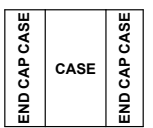
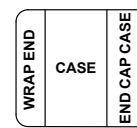
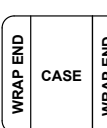
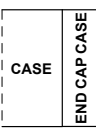
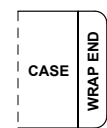
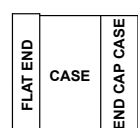
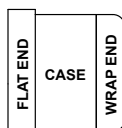
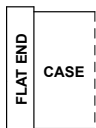
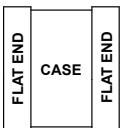



17" Glass Streamlyne Front



12" Glass Flat Front



7" Glass Streamlyne Front



Solid Front



Solid Classic 2 Front

Base Model Features

- Abundant product facings maximize display impact of this wide island case.
- Advanced coil and baffle design provides consistent temperatures throughout the spacious bin for maintaining product integrity.
- Bottom-mounted copper coil and lift-up fan plenum with easily-removable fan basket and motor assembly for ease of maintenance.
- Seamless tank liner provides positive drain runoff and enhanced sanitation.
- Removable casters for easy merchandiser unloading and movement during installation.

Available Options

- Available lengths 4', 6', 8', 10' and 12'.
- Fronts are available in solid or glass construction.
- Solid front options include: Standard Solid, Classic 2 and Fusion.
- Glass front options include: 7", 12" and 17" with streamlyne bumper or flat front.
- Custom colors, finishes and textures.
- Optional superstructure in three heights for display of non-refrigerated products.
- Adjustable lighted shelf or saddle basket options for use with superstructure to provide additional display space.
- Epoxy coated wire or plexiglas product stops available to fit with your store aesthetics.
- Adjustable wire racks provide display flexibility.
- PVC or aluminum tag molding are available to meet customer needs.
- Insulated ends available for placement against walls or cases.
- Polymer or stainless end trim available.
- Base frames available in 5" standard or 7" custom.
- Optional dual temp switch allow quick and easy change between medium and low temp applications for increased merchandising flexibility.
- Center sill piping with electrical conduit allows for store top piping convenience and ease of installation.
- Unitized design utilizes single-point connection for hook-up, reducing the number of connections and installs per line-up.
- Electrical or hot gas defrost are available to meet your particular engineering design preference.
- Optional electronic case controller manages case performance for consistent temperature and product integrity.
- Optional 9.5" and 14" utility box for refrigeration and electrical connections.
- Optional electrical outlet can be installed in the kick plate for easy power access.
- Configuration: Single wrap, double wrap or single / double flat ends, single unitized or double unitized.
- Combine the OWIZV with OWEZV wide island end cap to increase capacity and present shoppers with a continuous display of product.
- Narrow depth version available OWZGG.



Dover Food Retail
Conyers, GA USA
844.591.5937
hillphoenix.com

©2018 Hillphoenix, Inc.

Hillphoenix

